

AUTOMATIC PATTY FORMERS

FORME STANDARD - STANDARD FORMS - FORMES STANDARD - STANDARD FORMEN - FORMAS ESTÁNDAR

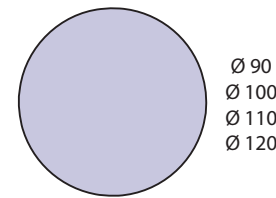

FORME SPECIALI - SPECIAL FORMS - FORMES SPECIALES - SONDER FORMEN - FORMAS ESPECIALES

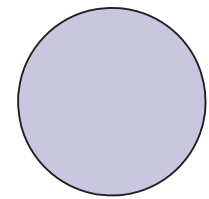

min. Ø 45
max. Ø 89

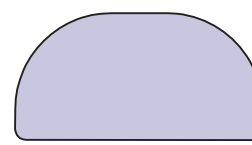

60 x 120
65 x 120

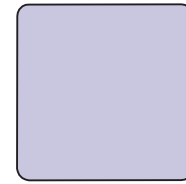

min. 60 x 60
max. 105 x 105

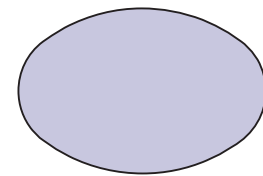

min. 60 x 80
max. 100 x 120

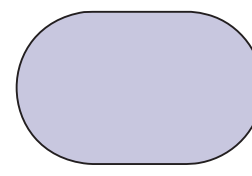

min. 50 x 80
max. 100 x 120



min. 25 x 60
max. 60 x 100

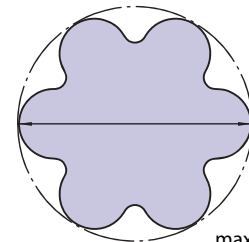

max. Ø 120

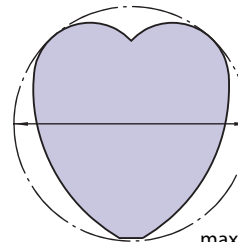

max. Ø 120

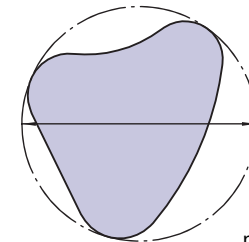

max. Ø 120

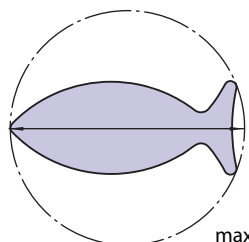

max. Ø 120

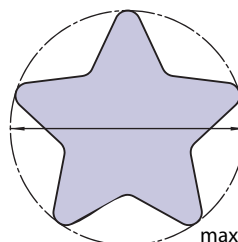

max. Ø 120

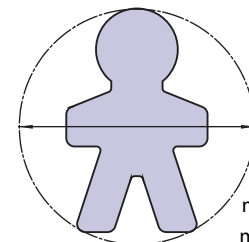

min. Ø 115
max. Ø 120

FORME SPECIALI DOPPIE - SPECIAL DOUBLE FORMS - FORMES SPECIAUX DOUBLES - SONDER DOBBELTE FORMEN - FORMATOS ESPECIALES DOBLES

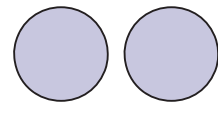

2 - min. Ø 36
2 - max. Ø 45

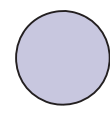

2 - min. Ø 25
2 - max. Ø 35



2 - min. 15 x min. 50
2 - max. 35 x max. 120

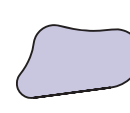

2 - 35 x 60

CARATTERISTICHE TECNICHE - TECHNICAL SPECIFICATIONS - TECHNISCHE DATEN - CARACTÉRISTIQUES - ESPECIFICACIONES

		C/E 652	C/E 653	C/E 653 R	C/E H	C/E H R
Capacità tramoggia - Feed pan capacity - Contenance tramié - Trichterinhalt - Capacidad tolva	l	18	23	23	30	30
Produttività - Productivity - Production - Leistung - Productividad	pcs/h	1.000	2100	2100	2100	2100
Motore trifase - Threephase motor - Moteur triphasé - Dreiphasigmotor - Motor trifasico	kW (HP)	0,3 (0,4)	0,75 (1)	0,75 (1)	0,75 (1)	0,75 (1)
Motore monofase - Singlephase motor - Moteur monophasé - Einphasigmotor - Motor monofasico	kW (HP)	0,3 (0,4)	0,65 (0,9)	0,65 (0,9)	0,75 (1)	0,75 (1)
Forma - Shape - Moule - Form - Forma	Ø mm	max 120				
Peso netto - Net weight - Poids net - Nettogewicht - Peso neto	kg	45	53	63	75	85

I dati del presente catalogo non sono impegnativi e potranno subire variazioni senza preavviso. Specifications and other features are subject to change without notice. (07/15)

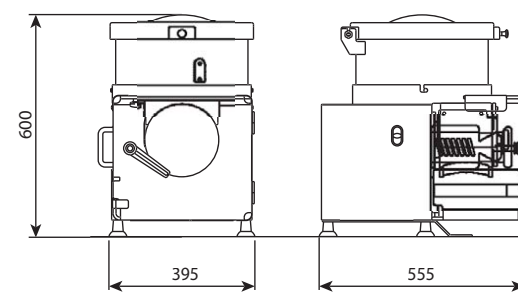

C/E 652

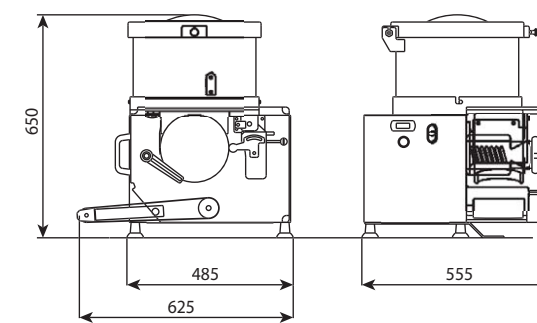

C/E 653 - C/E 653 R

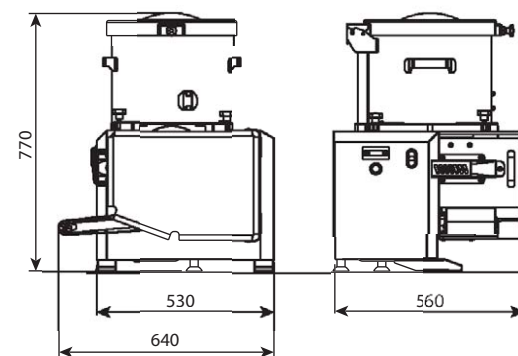

C/E H

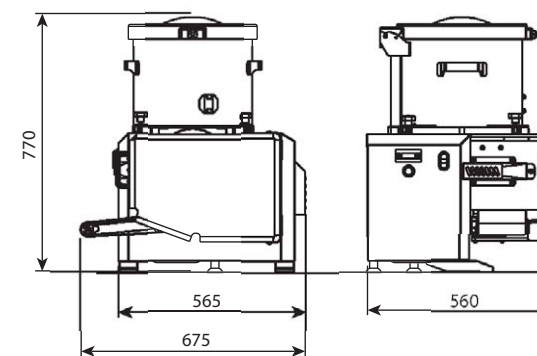

C/E H R



C/E 653

C/E H R



Macchine conformi alle norme CE in materia di igiene e sicurezza

Machines made according to CE hygiene and safety standards

Machines conforme aux normes CE en matière d'hygiène et de sécurité

Maschinen in Übereinstimmung mit CE Normen zu Hygiene- und Sicherheitsfragen

Máquinas conformas con las normas CE en materia de higiene y seguridad



Minerva Omega group s.r.l.
Via del Vetraio, 36 z.i. Roveri 2 - 40138 Bologna - Italy
tel. +39 051 530.174 - fax +39 051 535.327
laminerva@laminerva.it - www.laminerva.it
info@omegafoodtech.it - www.omegafoodtech.it
UNI EN ISO 9001: 2008 - REG. N. 9656-A



